

**Fujian, China - Zhangzhou**

**Fujian Jialong Adhesive Tape Co.,Ltd.**  
No.11 Xiazhai Road, Hua An County, Zhangzhou City,  
Fujian, 363000, China.  
Tel: +86-596-728-0001

**Fujian, China - Xiamen**

**Fujian Jialong Adhesive Tape Co.,Ltd. Xiamen Branch**  
20F Haiguang Building, No.33, Shuixian Road, Siming  
District, Xiamen, Fujian, 361001, China.  
Tel: +86-592-207-5506  
Email: info@jl3tape.com  
Web: www.jl3tape.com

**Guangdong, China**

**Fujian Jialong Adhesive Tape Co.,Ltd. Guangdong Office**  
Qinling Bld, No.1 East Kangle Road, Houjie Town  
Dongguan,Guangdong, 523960, China.  
Tel: +86-769-3386-2122

**Shanghai, China**

**Shanghai Jialong Fiber Tape Co.,Ltd.**  
No.80 Xiangmin Road, Chedun Town, Songjiang  
District, Shanghai, 201611, China.  
Tel: +86-21-5108-3676

**USA**

**Kingnode America Inc.**  
130 Spring Ridge Dr Roswell, GA, 30076, USA.  
Email: info@kingnodetech.com  
Web: www.kingnodetech.com



# Operating Manual



## E-404 Electric Water Activated Gummed Paper Tape Dispenser

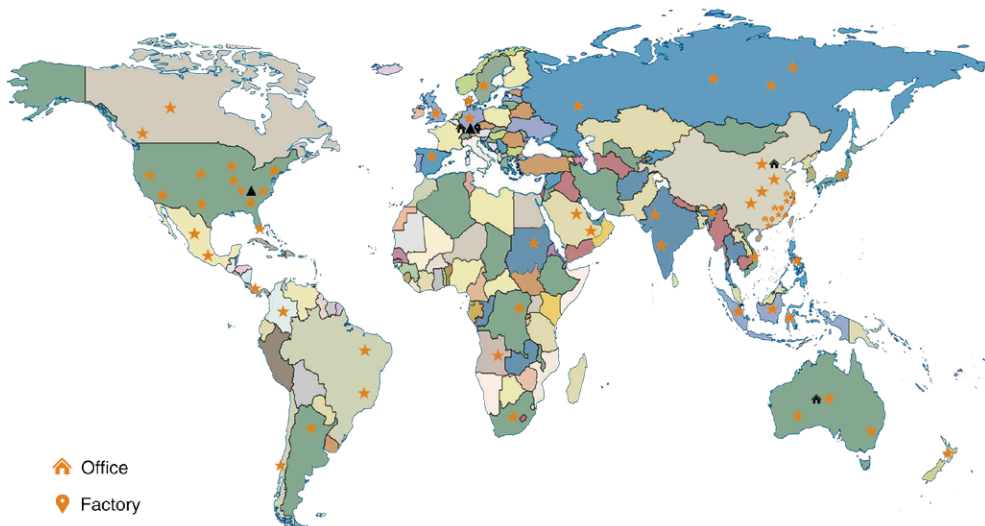

- Office
- Factory
- R & D
- Marketing Network
- In Planning



JLB Website



LinkedIn



Facebook



Kingnode Website

Manufacturer: Kingnode (Fujian) Technology Co., Ltd.  
Address: Jiulong Industry Park, Hua An, Zhangzhou, Fujian China.  
Consultation: info@kingnodetech.com  
Website: www.kingnodetech.com

## Part I Preface

### TABLE OF CONTENTS

Part I Preface -----	02
Part II Safety Precautions -----	03
Part III Technical Data and Illustration -----	04
Part IV CNC Operation Interface Directions -----	05
Part V Operating Instructions -----	09
Part VI Daily Maintenance -----	11
Part VII Common Troubleshooting -----	12
Part VIII After-Sales Service -----	13

Thanks for choosing model E-404 WAT (Water Activated Tape) Dispenser designed and produced by our company. Compared with similar equipment of other brands, this equipment has the following major advantages:

- ◆ It is applicable to 100V~240V, not subject to international regional voltage restrictions.
- ◆ E-404BH built-in large-capacity lithium battery, to ensure the smooth operation in case there is no power access or temporary power outage in the workplace.
- ◆ Equipped with CNC display screen and 10 digital mechanical keys, and built-in "automatic" and "manual" two operation modes, can meet the user's diversified sealing needs.
- ◆ Except E-404 model, other models of this series are equipped with thermostatic heating module, which can effectively ensure the tape been water activated evenly and excellent sealing effect even in low temperature environment.
- ◆ The "infrared induction" operation in the automatic mode of the equipment turns customization and user-friendly tape sealing into reality. which is very user-friendly, convenient and efficient.
- ◆ Equipped with movable pressure plate weight ( fixed on the bottom of the equipment tape outlet side ), Users can adjust the water uniformity of the tape by adding or reducing the quantity of movable pressure plate weight, both reinforced or non-reinforced water activated paper tape can be used.

In general, this cutting machine has the advantages of safety, efficiency, convenience and environmental protection. The design concept is leading and humanized. It is currently the world's leading WAT kraft paper tape dispenser. We hope it can bring you a different carton sealing experience.

This operating manual solely provides necessary information about the machine operation, maintenance and repair of the E series WAT Dispenser, Does not serve as a warranty of the product.

Disclaimer: in order to provide better assistance and guidance to our users, we reserve the right to make continuous necessary revisions and improvements to this operating manual without notifying users in advance. Please read this Operating Manual carefully before using the equipment to ensure that the operator fully understand the function and the performance of the machine, and make sure to handle this dispenser correctly and safely.

If you want to know more about this product or need help, please contact our company directly, our contact information is as follows:

Manufacturer: Kingnode (Fujian) Technology Co., Ltd.

Address: Jiulong Industry Park, Hua An, Zhangzhou, Fujian China.

Telephone: +86-400-6169-833

Mail: info@kingnodetech.com

Website: www.kingnodetech.com

## Part II Safety Precautions

In order to avoid personal injury caused by improper use of the equipment, please read and follow the safety instructions carefully:

1. Please read this operation manual carefully before using the equipment to ensure that you have fully understood the performance of the equipment and mastered the correct operation and maintenance methods.
2. If the machine is not installed and used in accordance with the operating instructions, this product may generate radio energy, which may cause interference to radio communications, however it fully complies with the relevant provisions of the FCC. If the device is used in a residential area, necessary measures need to be taken to eliminate the interference of the device with radio communications.
3. Prior to cleaning of the tape jam, make sure the power is turned off. When there is a need of professional cleaning for the equipment which might lead a breakdown or damage of the machine, you need to get a technician to service the machine specifically.
4. When the equipment is necessary to be moved to the next workplace, please ensure that the power is off, then remove the Water Bottle, Water Tank and the Moistening Brushes to prevent electric shock hazard due to the spill of water.
5. The remaining heat exists on the surface of the metal parts attached to the heater may cause severe skin burn. Please do not touch it without taking any protective measures.
6. Use of tape products or machine parts not recommended by the equipment manufacturer may increase unsafe factors.

## Part III Technical Data and Illustration

### Technical Parameter Data

Technical Data Of E-404 Series WAT Kraft Paper Tape Dispenser:

MODEL	E-404	E-404H	E-404BH
Carton Dimension (mm)	585*355*350	585*355*350	585*355*350
Product Dimension (mm)	510*252*266	510*252*266	510*252*266
Gross Weight (kg)	13	13.4	14.8
Net Weight (kg)	11.6	12	13.4
Electric Voltage (V)	100-240	100~240	100~240
Operating Frequency (Hz)	50~60	50~60	50~60
Battery Capacity (mA)	/	/	≤12500
Tape Width (mm)	≤76	≤76	≤76
Diameter Roll (mm)	≤200	≤200	≤200
Capacity Of Water Bottle (L)	1.73	1.73	1.73
Brushes Piece/Set	2	2	2
Moistening Pressure Plate Piece/set	2	2	2

### Illustration of the Machine

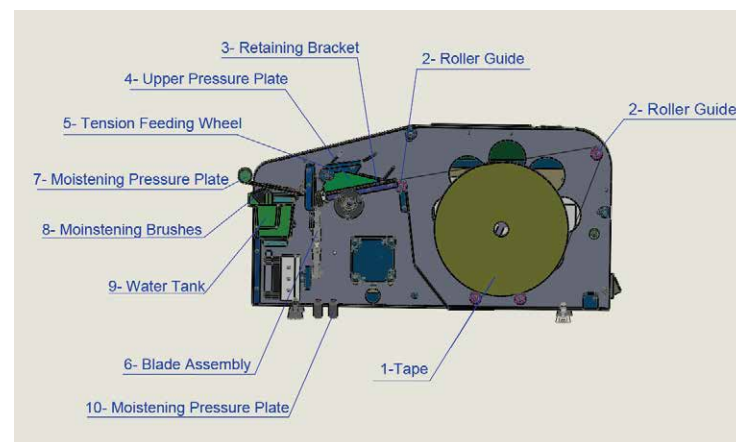

Figure 1: Illustration of the Machine

## Equipment Electrical Schematic Diagram

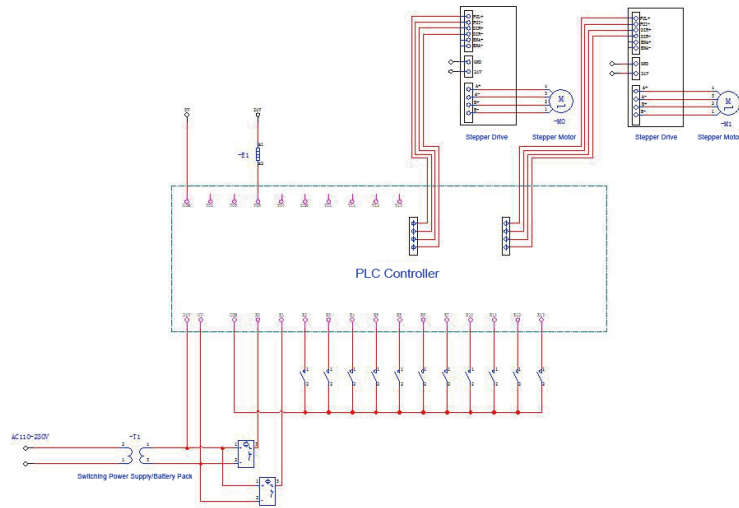

Figure 2: Equipment Electrical Schematic Diagram



Figure 3: Start-up Screen

## Interface 2: Program Setting

Program Setting 00 / 00 / 00 00: 00: 00						
No.	Length	Quantity	Actual	Setting	ON/OFF	Cumulative Meters
1	10	1	0	100	OFF	0.00
2	12	2	0	200	OFF	Induction Mode

Below the table, there are five control buttons: Stop, Reset, Heating, Automatic, and Setting.

Figure 4: Program Setting Interface

## Part IV CNC Operation Interface Directions

### Interface 1: Start-up Screen

When you turn on the power switch of the device, the CNC display screen will automatically enter the "startup interface" as shown in Figure 3. After the interface flashes for about 3 seconds, the device will automatically enter the "program setting" interface as shown in Figure 4.

This interface is composed of a combined cutting task editing area and eight function keys. The specific functions are introduced as follows:

### Introduction of function keys

1. Start/Stop: After setting the cutting length, press this button to start working.
2. Reset: Initial cutting length calibration, reset button.
3. Heating: Start the heating function of the water tank.
4. Setting: Press this function key to pop up the password input interface and enter the password (8888) to enter the "Manual Size Setting Of Equipment" interface as shown in Figure 5.
5. Cumulative meters: display the cumulative length of cutting tape (unit: M), Long press the display area for about 3 seconds to clear the data.
6. Automatic/Manual: Used for autonomous switching between automatic mode and manual mode.
7. Induction mode/automatic mode: in automatic mode cutting mode, it is used to switch between "induction mode" and "automatic mode".

### Combined Cutting Task Editing Area

1. Serial Number: The serial number of the work task instruction;
2. Length: Used to set the cutting length (unit: CM);
3. Quantity: Set the number of cut sheets corresponding to the specifications.
4. Actual: Display the number of sheets that have been cut.
5. Setting: used to set the total number of cut sheets corresponding to the specifications. When the "actual" number of sheets is equal to the "set" number of sheets, the device will automatically stop working.
6. On/Off: It is used to set the "on" or "off" status of the work task set in the corresponding work task row.

### Interface 3: Manual Mode Size Setting

Manual Setting for Length					
S/N	Length	Unit	S/N	Length	Unit
1	10	CM	6	60	CM
2	20	CM	7	70	CM
3	30	CM	8	80	CM
4	40	CM	9	90	CM
5	50	CM	10	100	CM

Parameter Return

Figure 5: Manual Mode Size Setting Interface

For this operation interface, the user can edit and set the cutting length corresponding to the 10 mechanical operation buttons according to actual needs. Press the "Return" in the lower right corner of this panel to return to the "Program Setting" interface, press the "Parameter" function key in the lower left corner and enter the password (6666) to enter the "Parameter Setting" interface as shown in Figure 6.

### Interface 4: Parameter Setting

Parameter Setting					
Pulse Speed	12000	Pcs/Sec	Total Blade Operation	0	Times
Acceleration Time	100	Ms	Total Cutting Length	0,00	Mts
Size Rectification	490	Mp	Daily Cutting Length	0,00	Mts
Delay Setting	5	Sec	Language Setting	English	Chinese

Device Information Return

Figure 6: Parameter Setting Interface



The specific description of the items displayed on this interface as follows:

- (1) Pulse Speed: Display the pulse speed of feeding motor (factory setting: 12000 pcs/sec). Parameter adjustment will affect the cutting accuracy of the equipment. Non-professionals should not modify it at will.
- (2) Acceleration Time: Display the time of the feeding motor to reach the set pulse speed (factory setting: 100Ms).
- (3) Size Rectification: Display the cutting calculation multiple of the device (factory setting: 490 magnification), which affects the cutting accuracy. If there is a deviation, you can make fine adjustments in units of 1 magnification, and do not adjust them significantly.
- (4) Delay Setting: It is used to set the cutting-interval time under Automatic Mode ( Factory Setting: 3 seconds), and the user can modify it according to actual demand.
- (5) Language Setting: Chinese and English switching.
- (6) Total Blade Operation: Display the cumulative use times of the blade. Long press the function key for 3 seconds to clear the data.
- (7) Total Cutting Length: Display the accumulated length of cutting length, in meters. Long press the display area for 3 seconds to clear the data.
- (8) Daily Cutting Length: Display the total length of cutting tape on the day, in meters. Long press the function key for 3 seconds to reset the data.
- (9) Device Information: Press this function key and enter the password (6666) to enter the "Device Information" interface.

## Part V Operating Instructions

This part will introduce the specific operation of E-404 series water activated paper tape dispensers.

### 1. First Step: Filling Water.

Remove the water bottle( black) and the side water tank (white) from dispenser in turns. Fill water up to 4/5 of water bottle and fill water full of water tank. Install water bottle and water tank back to the original position to finished the filling process.

### 2. Second Step: Increase/Decrease Weight on Pressure Plate.

When chose reinforced water activated tape, the weight (fixed on the press plate and needs to unscrew) on press plate needs to be installed into the cylinder to ensure the tape wet evenly. When choose non-reinforced water activated tape, do not need to install weights to avoid any blocks in channel or unevenly wet on the tape.

### 3. Third Step: Install the Tape Roller.

Open the front and rear covers, pull the spring pressure roller and remove the pressure plate. Place the water activated tape (Glue side should be up) between the two rollers in the dispenser channel. Pull the tape (front-end) backwards through the feed roller (glue side will be down) and make it under the pressure roller. Put the press plate back to its original position to complete the installation.

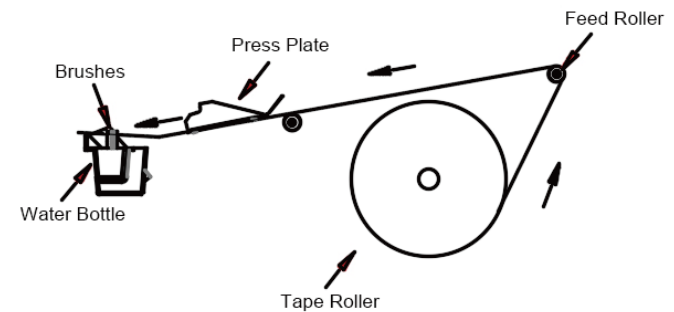

Figure 5: Introduction Diagram for Placing the Tape Roller

### 4. Fourth Step: Operation Mode and Operation Method.

In order to meet diversified sealing needs, this dispenser is equipped with two modes, Automatic Mode and Manual Mode, and users can choose according to actual needs.

Manual Mode is suitable for application scenarios where multiple specifications are frequently switched. The specific operation method: According to the actual cutting length, Modify the cutting length corresponding to the 1-10 mechanical digital keys in the "Manual Setting for Length" interface (factory setting value: 10, 20, 30...100) . Press the "return" button to return to the "program setting" interface. Press the "start" button, and then press the mechanical number keys to conduct the tape cutting operation.

Automatic Mode is suitable for two-lengths combined cutting, and is mainly used for sealing in ways, "工" or "H" . There are two specific operation methods as follows:

(1) Method 1

- A. Turn on the task "On/Off" in the "Program Setting" interface.
- B. Switch to Automatic Mode.
- C. Turn on the Sensor Mode.
- D. Press "Start".
- E. Reach out to the sensing area to get the cut tape for sealing operation.
- E. Reach out to the sensing area to get the cut tape for sealing operation.

(2) Method 2

- A. Turn on the task "On/Off" in the "Program Setting" interface.
- B. Switch to Automatic Mode.
- C. Press "Start".
- D. Reach out to the sensing area to get the cut tape for sealing operation.

## Part VI Daily Maintenance

In order to achieve the best results, in the process of using the E-404 series water activated tape dispenser, users need to perform necessary and simple maintenance. As a supplier of this equipment, we recommend the following daily maintenance work:

1. Check the water level of the water tank frequently to avoid the poor effect of the tape wet due to lack of water in the water tank.
2. Regularly clean the water brushes, water tank and water storage tank with soapy water to avoid the accumulation of adhesive and affect the wet water effect of the tape.
3. Regularly use lubricating oil to lubricate the rotating parts of the equipment, such as the bearings and transmission belts, to avoid inflexible parts that cause running jams or blockages.
4. When the tape is jammed, carefully check and clean the channel to avoid another paper jam.

## Part VII Common Troubleshooting

During use, some minor faults may occur due to improper installation or operation. In order not to affect your work, we recommend that you first check and resolve the faults according to the following methods.

No.	Failure Description	Possible Reasons	Solution
1	External power is applied, but the device does not start normally.	(1) The device switch is not turned on. (2) The equipment plug is not properly inserted. (3) The electric outlets are not working.	(1) Turn on the power switch of the equipment. (2) Make sure the equipment is plugged in. (3) Turn on the electric outlets or insert the plug into a power socket.
2	No access to an external power source, the device can not be started properly.	(1) The device switch is not turned on. (2) The battery is low or exhausted.	(1) Turn on the power switch of the equipment. (2) Move the device to a place with external power supply for charging.
3	The device can be turned on normally, but the device did not execute the cutting command to cut the tape when it reached out to take the tape.	(1) The work order is not opened and is in the "OFF" state. (2) The position where the operator extends the hand is not within the sensing area of the infrared sensor of the equipment.	(1) Enter the task editing interface, click the task status button, and switch "OFF" to "ON". (2) Reach out your hand within the sensing area of the infrared sensor of the device.
4	The tape is not evenly wet and sealed nonstick.	(1) There is adhesive residue on the channel, water brush or outlet of the water tank. (2) Insufficient water in the water tank or storage tank. (3) The user has replaced the unqualified wet water brushes or placed the wet water brushes improperly. (4) Poor quality of the adhesive tape selected by the user. (5) Unevenly press the tape during the sealing process.	(1) Thoroughly clean the tape channel, water brushes or outlet of water tank, and perform regular maintenance as required. (2) Add an appropriate amount of water to in water tank. (3) Purchase and use qualified water brushes, and place the brushes as required. (4) Purchase and use qualified tape; If use reinforced water activated tape, users need to install weights on pressure plate. (5) Press the surface of the tape evenly and make it evenly stressed during the sealing process.
5	The tape is often wrinkled, jammed or jammed during use.	(1) Improper installation method of tape roll. (2) Adhesive residues accumulate on the channel or water brushes. (3) The tape selected by the user with poor quality.	(1) Re-install the tape roll as required, especially check whether the pressure plate is placed correctly. (2) Check and thoroughly clean the channel or water brushes, and perform regular maintenance as required. (3) Purchase and use qualified tape.
Remark: If the problem is still not resolved through the above troubleshooting, please contact our professional after-sales service personnel.			

## Part VIII After-Sales Service

The warranty period is one year from the date of purchase of the equipment. We provide the service of repairing and replacing defective parts of the machine free of charge during this period.

The expired warranty period and the repair services outside the warranty range are not covered by the warranty. The repair cost will be charged under the following situations:

1. The damages caused by equipment handling, equipment installation and improper use;
2. The damages caused by natural disasters or other force majeure factors if user arranges transportation individually;
3. The damages caused by individually dismantling or replacing any internal components of the equipment;
4. The equipment is damaged due to the guidance of non-our professional technicians or failure to follow this operation manual;
5. Quick-wear part such as blades, water tanks, brushes, etc. are not covered by the warranty.

### Water Activated Tape Dispensers Appendix:

No.	Item No.	Product Name	Remark
1	P-104	Pull and Tear Water Activated Dispenser	
2	M-204	Manual Water Activated Dispenser	
3	E-304	Electric Water Activated Dispenser	
4	E-304H	Electric Water Activated Dispenser (with heater)	
5	E-304BH	Electric Water Activated Dispenser(with lithium battery and heater)	
6	E-304HL	Electric Water Activated Dispenser(larger size with heater)	
7	E-404	Electric Water Activated Dispenser	
8	E-404H	Electric Water Activated Dispenser(with heater)	
9	E-404BH	Electric Water Activated Dispenser(with lithium battery and heater)	

## Appendix: Maintenance Service / Repair Record

### Maintenance Service / Repair Record Card

User Information				
Customer Name		Purchase Date		
Model No.		Telephone Number		
Email Address		Postal code		
Address				
Dealer Information				
Dealer Name		Telephone Number		
Email Address		Postal Code		
Address				
Maintenance Records				
S/N	Warranty Reasons	Repair Content	Customer Acceptance	Maintenance Personnel
1				
2				
3				
4				
5				
6				
7				
8				
9				
10				
11				
12				